

DUBLIN INSTITUTE OF TECHNOLOGY  
BOLTON STREET, DUBLIN 1

---

# Bachelor of Engineering (Honours) in Structural Engineering

---

THIRD YEAR: JANUARY 2008  
SEMESTER 1

---

STRUCTURAL ANALYSIS III

John Turner, B.E., M.Eng.Sc., M.I.E.I.  
Joseph Kindregan, BE  
Colin Caprani, Ph.D., B.Sc.(Eng.), Dip.Eng., C.Eng., M.I.E.I., M.I.A.B.S.E., M.I.Struct.E.

**Someday, XXth January, 09.30 a.m. to 12.30 p.m.**

Answer *all* of the following *three* questions.

Question 1 carries 20 marks; Questions 2 and 3 carry 40 marks each.

Time Allowed : 2 Hours

*Given:*

**SAMPLE PAPER**

1. (a) Classify each of the structures shown in Fig. Q1(a), indicating whether the structure is unstable or stable and statically determinate or indeterminate (giving the degree of indeterminacy).

(10 marks)

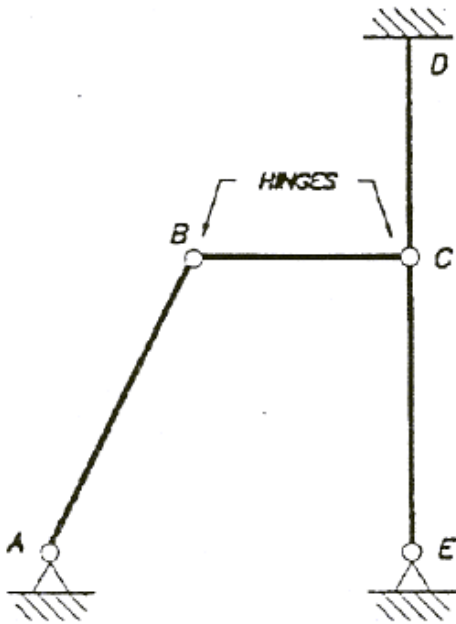

FIG Q1(a)(i)

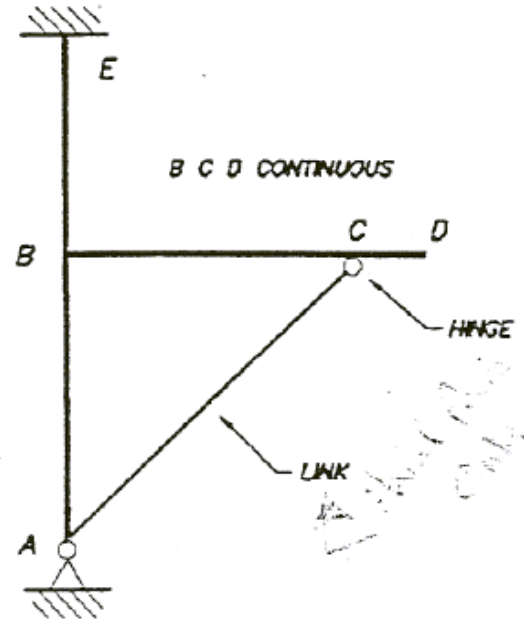

FIG Q1(a)(ii)

- (b) Determine the degree of kinematic indeterminacy of the structures shown in Fig. Q1(b), stating briefly reasons for your answer and any assumptions made about axial deformations.

(10 marks)

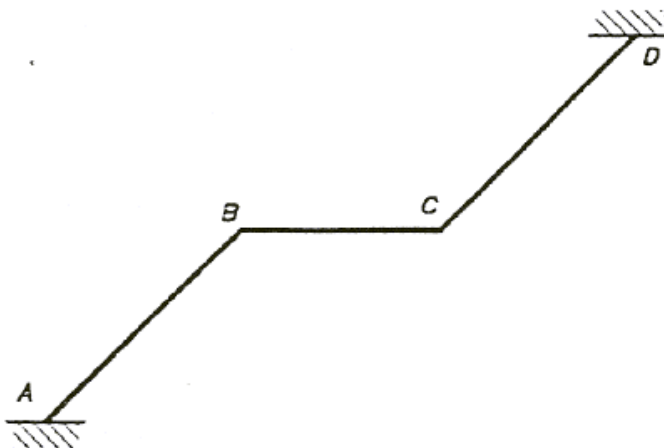

FIG Q1(b)(i)

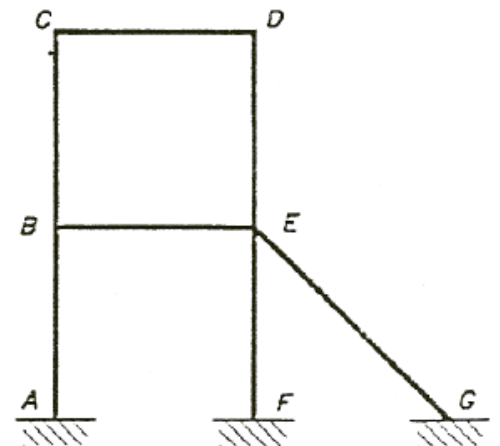

FIG Q1(b)(ii)

2. Using *Moment Distribution*:

- (i) Determine the bending moment moments for the frame in Fig. Q2;
- (ii) Draw the bending moment diagram for the frame, showing all important values;
- (iii) Draw the deflected shape diagram for the frame.

(40 marks)

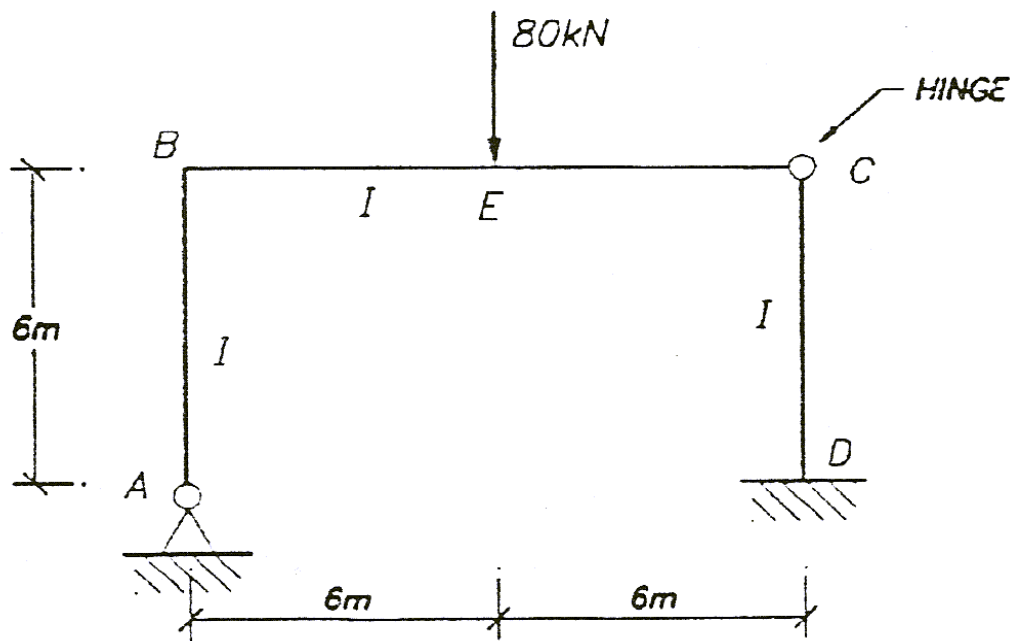

FIG Q2

3. For the frame shown in Fig. Q3, using the *Moment-Area Method (Mohr's Theorems)*:
- Draw the bending moment diagram;
  - Determine the horizontal deflection of joint *D*;
  - Draw the deflected shape diagram for the frame.

**Note:**

You may neglect axial effects in the members.

Take  $EI = 4 \times 10^3 \text{ kNm}^2$  for all members.

(40 marks)

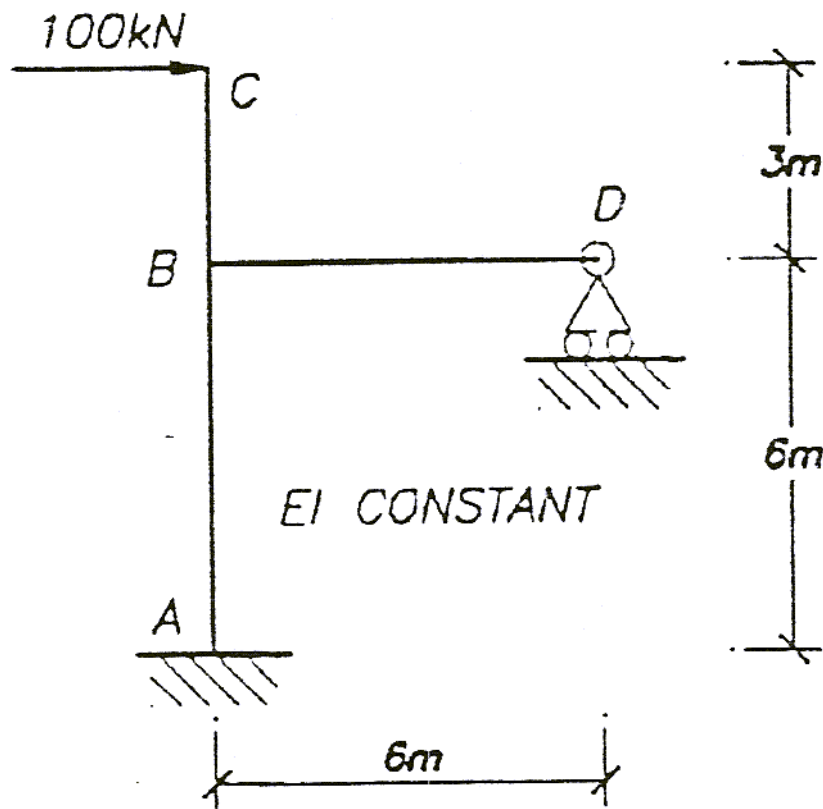

**FIG. Q3**

## Fixed-End Moments

### Loading

$M_A$	Configuration	$M_B$
$+\frac{PL}{8}$		$-\frac{PL}{8}$
$+\frac{wL^2}{12}$		$-\frac{wL^2}{12}$
$+\frac{Pab^2}{L^2}$		$-\frac{Pa^2b}{L^2}$
$+\frac{3PL}{16}$		-
$+\frac{wL^2}{8}$		-
$+\frac{Pab(2L-a)}{2L^2}$		-

### Displacements

$M_A$	Configuration	$M_B$
$+\frac{6EI\Delta}{L^2}$		$+\frac{6EI\Delta}{L^2}$
$+\frac{3EI\Delta}{L^2}$		-

## Displacements

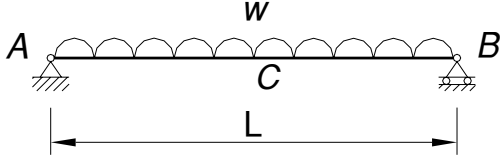
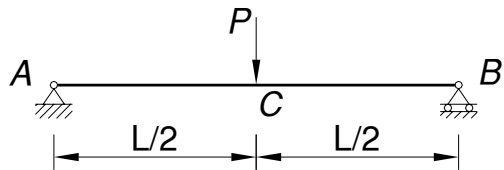
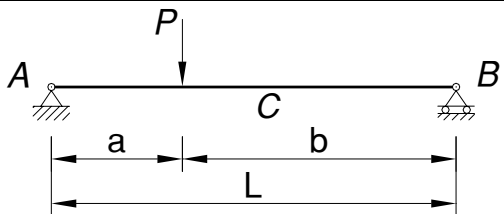
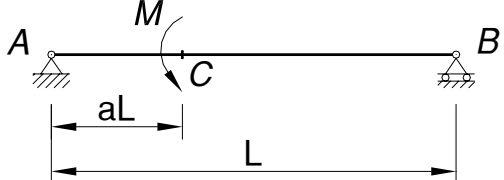
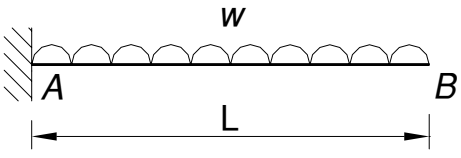
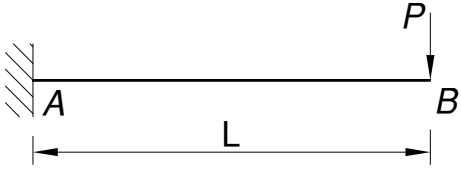
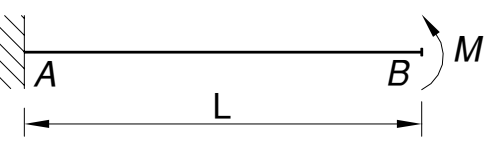
Configuration	Translations	Rotations
	$\delta_C = \frac{5wL^4}{384EI}$	$\theta_A = -\theta_B = \frac{wL^3}{24EI}$
	$\delta_C = \frac{PL^3}{48EI}$	$\theta_A = -\theta_B = \frac{PL^2}{16EI}$
	$\delta_C \cong \frac{PL^3}{48EI} \left[ \frac{3a}{L} - 4 \left( \frac{a}{L} \right)^3 \right]$	$\theta_A = \frac{Pa(L-a)}{6EI} (2L-a)$ $\theta_B = -\frac{Pa}{6EI} (L^2 - a^2)$
	$\delta_C = \frac{ML^2}{3EI} a(1-a)(1-2a)$	$\theta_A = \frac{ML}{6EI} (3a^2 - 6a + 2)$ $\theta_B = \frac{ML}{6EI} (3a^2 - 1)$
	$\delta_B = \frac{wL^4}{8EI}$	$\theta_B = \frac{wL^3}{6EI}$
	$\delta_B = \frac{PL^3}{3EI}$	$\theta_B = \frac{PL^2}{2EI}$
	$\delta_B = \frac{ML^2}{2EI}$	$\theta_B = \frac{ML}{EI}$